

ID31 Stepper Motor Information Sheet

1. General

The ID31 is a permanent magnet four-phase stepper motor, having a 7.5° step angle. It has a permanent magnet rotor, and a stator consisting of four d.c. windings.

The four windings are switched on and off in a fixed pattern to produce each step of the rotor. The rotor can be driven clockwise or anti-clockwise and the motor can be used for position control (by stepping through the desired angle) or for speed control (by varying the stepping rate).

Because it uses a permanent magnet, this motor still has some holding torque even when switched off.

2. Connection Data

The four windings are brought out to six terminals in the side of the casing as shown in Fig. 1. 1' and 2' are connected together inside the case and brought out to a single terminal, as are 3' and 4'. In most applications, 1' 2' 3' and 4' are all connected together.

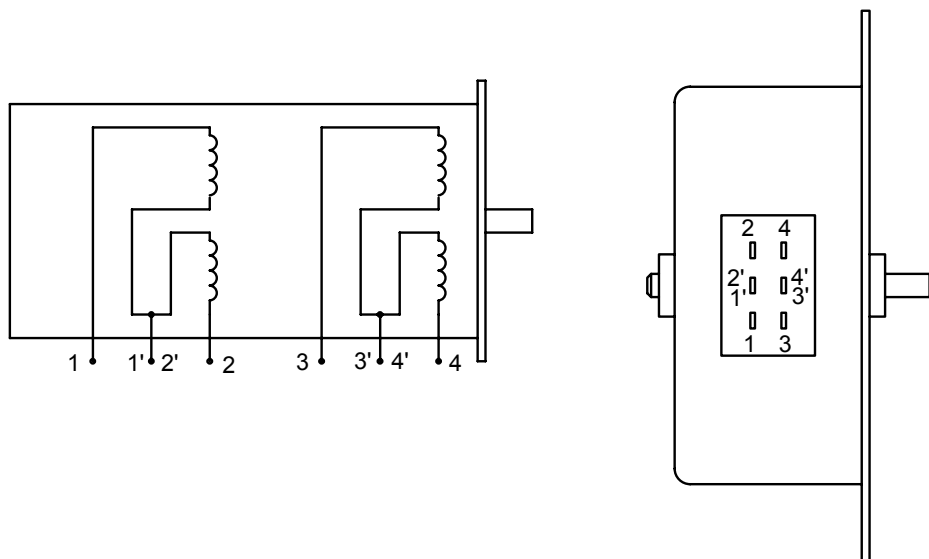

Figure 1. ID31 Stepper Motor Winding Connections

3. Switching sequence

Table 1 shows the switching sequence necessary to drive the motor in the full step mode.

WINDINGS				
	1	2	3	4
STEP 1	ON	OFF	OFF	ON
STEP 2	ON	OFF	ON	OFF
STEP 3	OFF	ON	ON	OFF
STEP 4	OFF	ON	OFF	ON
STEP 1	ON	OFF	OFF	ON

Table 1 Full Step Switching Sequence

After step 4, the sequence is repeated. To reverse the direction, simply reverse the sequence. This is known as full step mode, and results in steps of 7.5° i.e. 48 steps per revolution.

The motor can also be driven in half step mode, i.e. steps of 3.75° or 96 steps per revolution.

Table 2 shows the sequence for half step mode.

WINDINGS				
	1	2	3	4
STEP 1	ON	OFF	ON	OFF
STEP 2	ON	OFF	OFF	OFF
STEP 3	ON	OFF	OFF	ON
STEP 4	OFF	OFF	OFF	ON
STEP 5	OFF	ON	OFF	ON
STEP 6	OFF	ON	OFF	OFF
STEP 7	OFF	ON	ON	OFF
STEP 8	OFF	OFF	ON	OFF
STEP 1	ON	OFF	ON	OFF

Table 2. Half Step Switching Sequence

The half step sequence does not produce as much torque as the full step sequence, so it is usually better to use gearing if a finer angle is required.

4. Driving Stepper Motors from a Deltronics Control Box

Any Deltronics Control Interface can be used to drive stepper motors. The old Control It box, The Serial Interface (including COMMOTION), Control It Plus, or the Junior Serial Interface.

Four outputs per motor are required, so all the interfaces can drive two stepper motors, except the Junior Serial Interface which can drive one stepper motor.

The motor should be connected as shown in Fig 2.

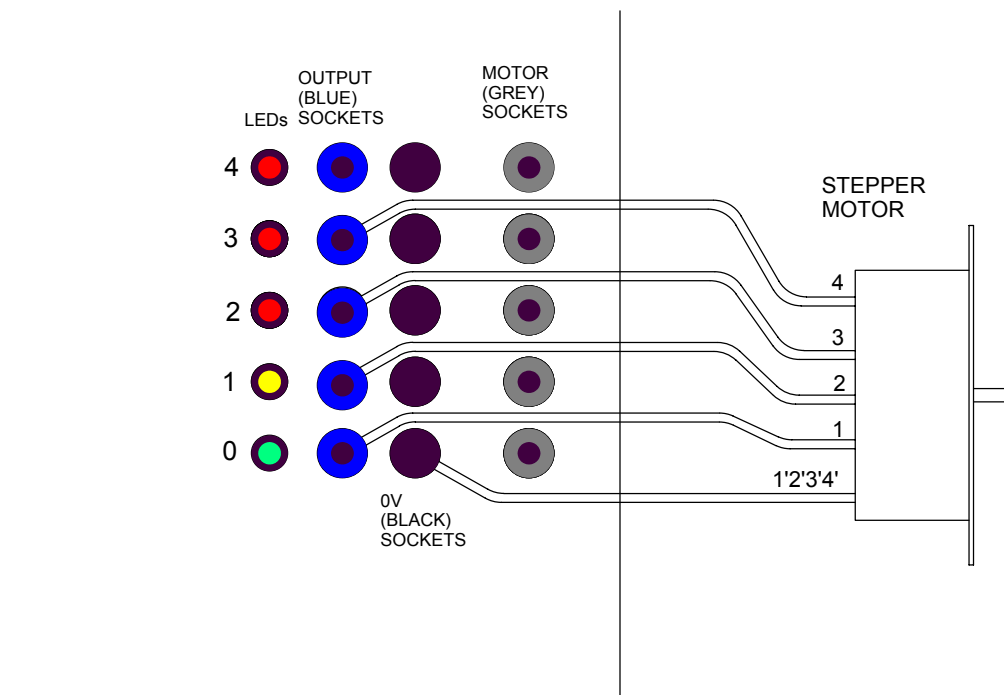

Figure 2. Connecting a stepper motor to a control box

Note: Control It Plus is shown. There will be minor differences between the various other interfaces, but as long as the motor is connected to the bottom four outputs then it will work. *Do not use the grey motor sockets.*

5. Software

The program must produce the correct sequence for driving the motor. Referring to Table 1 and translating the ON and OFF states to 1 and 0, the sequence becomes –

1	0	0	1
1	0	1	0
0	1	1	0
0	1	0	1

Translating these into decimal numbers gives 9, 10, 6 and 5

5.1 Programming with Control It PC (and Control95 and Junior Control)

A procedure to make the motor take one step can be written in Control It PC (the same procedure will work with Control 95 and Junior Control)

Create a procedure called **step**.

```
If X=9 then Y=10
If X=10 then Y=6
If X=6 then Y=5
If X=5 then Y=9
Output Y
X=Y
```

The procedure simply outputs the correct number depending on the previous number. It is important to set X to the new number (in the last line of the procedure) otherwise the sequence would remain in the same place.

Now you can call **step** repeatedly to make the motor turn through the required angle. e.g. to turn through 90 degrees (12 steps)

```
X=9
Repeat 12
  Step
Next
```

Note: it is important to initialise X first.

5.2 Programming in other languages

It is easy to program the sequence in any language, as long as the correct sequence is generated, it will work. The easiest way is to create an array with four elements (9, 10, 6 and 5) then increase the index to the array for each step. After 3, reset the index to 0

6. Connecting a second motor

A second motor can be connected to the upper four outputs; in this case, the numbers in the sequence should be multiplied by 16 to shift them into the upper half. Multiplying by 16 results in a sequence of 144,160,96 and 80. These numbers must be added to those for the lower motor to obtain the correct number for output.

7. Technical data

Part No.	ID31 9904 112 31004	
Step Angle	7.5	Degrees (full step)
Holding Torque	28	mNm
Working Torque	20	mNm
Current/Phase	175	mA
Resistance/Phase	65	Ohms
Nominal Operating Voltage	12	V

Physical Dimensions

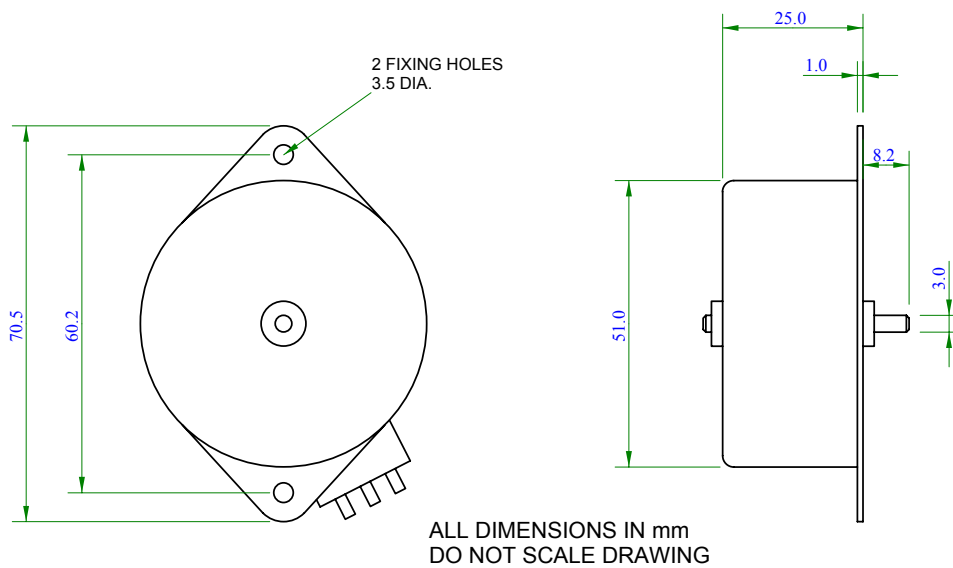

8. Mechanical

The use of gears or pulleys and belts enables finer step angles and greater torque to be produced. The use of rack and pinion, lead screws, cams etc. enables rotational steps to be translated into linear steps.

DISCLAIMER:

This information is provided as is, and has no warranty, implied or otherwise. You are free to use it at your own risk.

DELTRONICS SHALL NOT BE LIABLE FOR ANY LOSS OR CONSEQUENCE RESULTING FROM THE USE OF THIS INFORMATION, NOR FOR INDIRECT, SPECIAL, INCIDENTAL OR CONSEQUENTIAL DAMAGES OF ANY KIND WHETHER UNDER THIS AGREEMENT OR OTHERWISE, EVEN IF ADVISED OF THE POSSIBILITY OF SUCH DAMAGES.